

2 - 5/8" Dia Equip Mtg Holes for 1/2" Dia Bolts ( by others )

2 - 5/8" Dia Hole for Fdtn Bolts

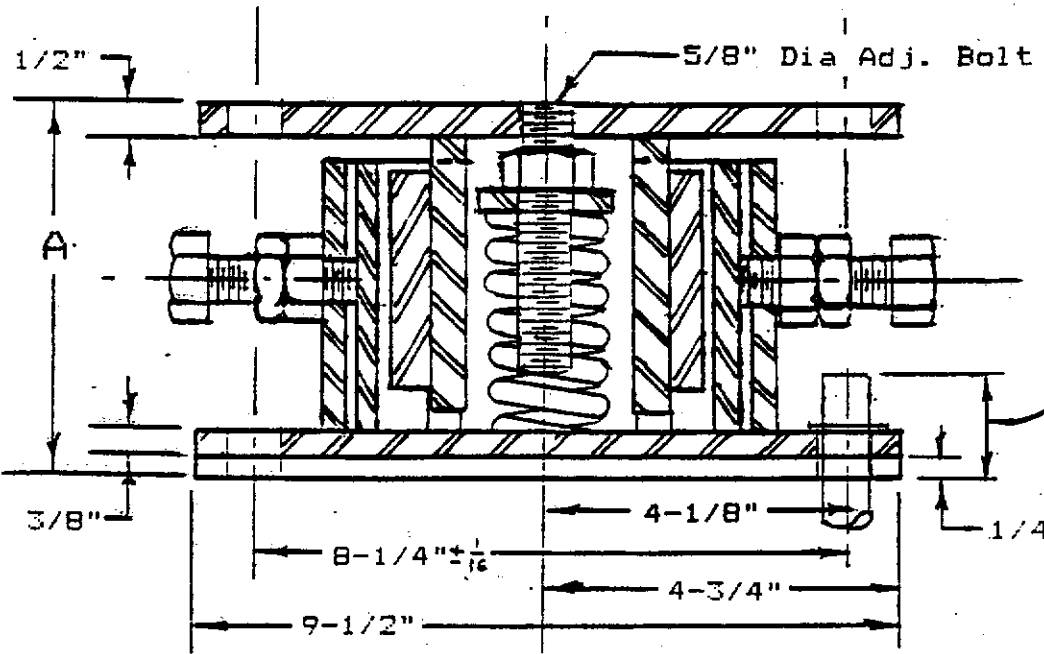

1-1/2" Max Proj of 1/2" Dia Fdtn Bolts w/ Std Stl Washer & Heavy Jam Nut ( by others )

1/4" Sound Pad

ISOL. NO.	RATED LOAD		"A" MIN FREE HT.
	STEADY	IMPACT	
W I 2-1	250	---	6 5/8
W I 2-2	400	---	
W I 2-3	600	---	
W I 2-4	1000	---	
W I 2-5	1400	---	
W I 2-6	2400	---	5 1/4
W I 2-S5	650	520	
W I 2-S6	900	720	
W I 2-S7	1200	960	
W I 2-S8	2200	1650	5 5/8
W I 2-S9	2600	2450	

Min. Oper. Ht 5-1/8"  
or Free Ht minus Oper Deflection  
Whichever is Greater

UNLESS INDICATED  
DECIMALS ± 1/16"  
FRACTION ± 1/8"  
ANGLES ±  
RMS FINISH:  
✓ MIL-STD-10  
SCALE: N.T.S.

ASSEMBLY  
TYPE WI-2 COMBINED SNUBBER  
VIBRO ISULATOR

ISOLATION TECHNOLOGY INC.  
P.O. BOX 480  
MASSAPEQUA, N.Y. 11758

012391-1